

TCM

FB-VIII SERIES
ELECTRIC COUNTERBALANCED FORKLIFT TRUCKS



1.0-3.5 tons

Class 1 - sit-down type

SPECIFICATIONS

STANDARD SPECIFICATIONS

Characteristics			TCM						
			FB10-8	FB15-8	FB18-8	FB20-8	FB25-8		
1	Manufacturer		TCM						
2	Model		FB10-8	FB15-8	FB18-8	FB20-8	FB25-8		
3	Load Capacity	kg	1000	1500	1750	2000	2500		
4	Load Center	mm	500						
5	Power Type		Battery						
6	Control Type		Sit - Down Rider Type						
7	Tire Type	Front / Rear	Pneumatic						
8	Wheels (X = driven)	Front / Rear	2 x / 2						
Dimensions	9	Maximum Fork Height	3000						
	10	Free Lift	155		110				
	13	Fork Size	L x W x T		920 x 100 x 35				
	14	Tilt Angle	Fwd / Bwd		6 / 12				
	15	Length to Fork Face	1955	2055	2245	2285			
	16	Overall Width	1070		1150				
	17	Mast Height Fork Lowered	1995		2030				
	18	Overall Height Fork Raised	4030						
	19	Overhead Guard Height	2080 (2140 ⁴)		2125 (2185 ⁴)				
	21	Turning Radius (Outside)	1800 (1700 ⁵)		1890 (1790 ⁵)	2070 (1950 ⁵)	2100 (1970 ⁵)		
22	Fork Overhang(Centerline of front axle to front face of forks)	375		435					
23	Right Angle Stacking Aisle with pallet 1100 x 1100mm (clearance = 200 mm)	3475		3565	3805	3835			
Performance	24	Travel Max. ¹⁾ (Fwd / Rvs.)	With Load	14.0					
			Without Load	16.0					
	25	Lifting ¹⁾	With Load	390	350	330	290	265	
			Without Load	580		510			
	26	Lowering	With Load	430		450			
Without Load			520		500				
27	Max. Drawbar Pull ²⁾	momentary / continuous	7.5 / 3.0		8.9 / 3.5				
29	Gradeability ²⁾	with / without Load	14.3 / 20.0		14.3 / 16.7				
Weight	32	Total Weight (without battery)	2030	2050	2100	2700	3030		
	33	Weight Distribution (with STD capacity battery)	With Load	Front	2900	3720	4200	4800	5620
				Rear	780	490	580	700	790
	34	Without Load	Front	1200	1170	1320	1460	1450	
Rear			1480	1540	1710	2040	2460		
Chassis	35	Tires	Number	2 / 2					
	36	Size	Front	6.00 - 9 - 10PR	6.00-9-12PR	21 x 8 - 9 - 16PR			
			Rear	16 x 6 - 8 - 10PR		18 x 7 - 8 - 14PR			
	38	Wheelbase	mm	1250	1350	1400			
	39	Tread	Front	910		955			
			Rear	900		950			
	40	Ground clearance	at lowest point	90		100			
Frame			95		115				
42	Brake	Service	Hydraulic - Foot pedal						
		Parking	Mechanical - Hand lever						
Electric Motors and Control	45	Battery ³⁾ (STD capacity type)	Voltage / Capacity(5-hour rating)	V / AH	48 / 330	48 / 400	48 / 450	48 / 565	
	46	Weight with case	kg	650	660	930	800	880	
	47	Electric Motors	Drive motor(AC)	kW / 60min.	6.9		8.5		
			Hydraulic motor(AC)	kW / 5min.	8.6		9.0		
			Steering motor(DC)	kW / 60min.	0.35		0.55		
	54	Control Type	Drive	FET inverter					
			Load handling	FET inverter					
Power steering			FET chopper						
57	Operating Pressure ⁵⁾	For Attachment	MPa(kg/cm ²)	14.2 (145) ⁶⁾	15.7 (160) ⁶⁾	17.2 (175)			

NOTE: 1) Above figures are measured at "Super-mode" operation 2) Computed Values 3) Batteries are optional equipment 4) For European and Scandinavian export trucks
5) Figures are given for trucks with optional EPS 6) Fingertip control - 17.2MPa(175kg/cm²)

STANDARD SPECIFICATIONS

		TCM				
		FB25-8LB	FB25-8V	FB30-8	FB30-8V	FB35-8S
		2500	3000			3500
		500				
		Battery				
		Sit - Down Rider Type				
		Pneumatic				
		Pneumatic			Pneumatic/SE	
		2 x / 2				
		3000				
		110	165		170	
		1070 x 122 x 40		1070 x 125 x 45		1070 x 150 x 50
		6 / 12				
		2390	2510		2735	
		1150	1225		1380	
		2180	2030	2075	2135	
		4030		4260		4260
		2250	2100	2190 (2250 ⁴)	2100	2190 (2250 ⁴)
		2200 (2065 ⁵)		2290 (2140 ⁵)		2500 (2360 ⁵)
		435	480		500	
		3935	4070		4300	
		13.5	14.0			
		15.5				
		265	290		240	
		510	490		410	
		450				
		500	450			
		8.9 / 3.5		10.0 / 4.0		
		12.5 / 16.7		12.5 / 16.7		10.0 / 16.7
		2960	2965	3530	4015	
		5780	5740	6720	7750	
		1120	1050	920	990	
		1760	1720	1885	2310	
		2460	2570	2775	2930	
		2 / 2				
		21 x 8 - 9 - 16PR		28 x 9 - 15 - 14PR		250 - 15 - 16PR
		18 x 7 - 8 - 14PR		18 x 7 - 8 - 14PR		18 x 7 - 8 (SE)
		1545		1600		1800
		955		1000		1140
		950				
		100		90		
		115		120		
		Hydraulic - Foot pedal				
		Mechanical - Hand lever				
		48 / 935	48 / 865	72 / 450		72 / 450
		1440	1325	1110		1225
		8.5		11.9		
		9.0		14.0		
		0.55				
		FET inverter				
		FET inverter				
		FET inverter				
		FET chopper				
		17.2 (175)				

LOAD CHART

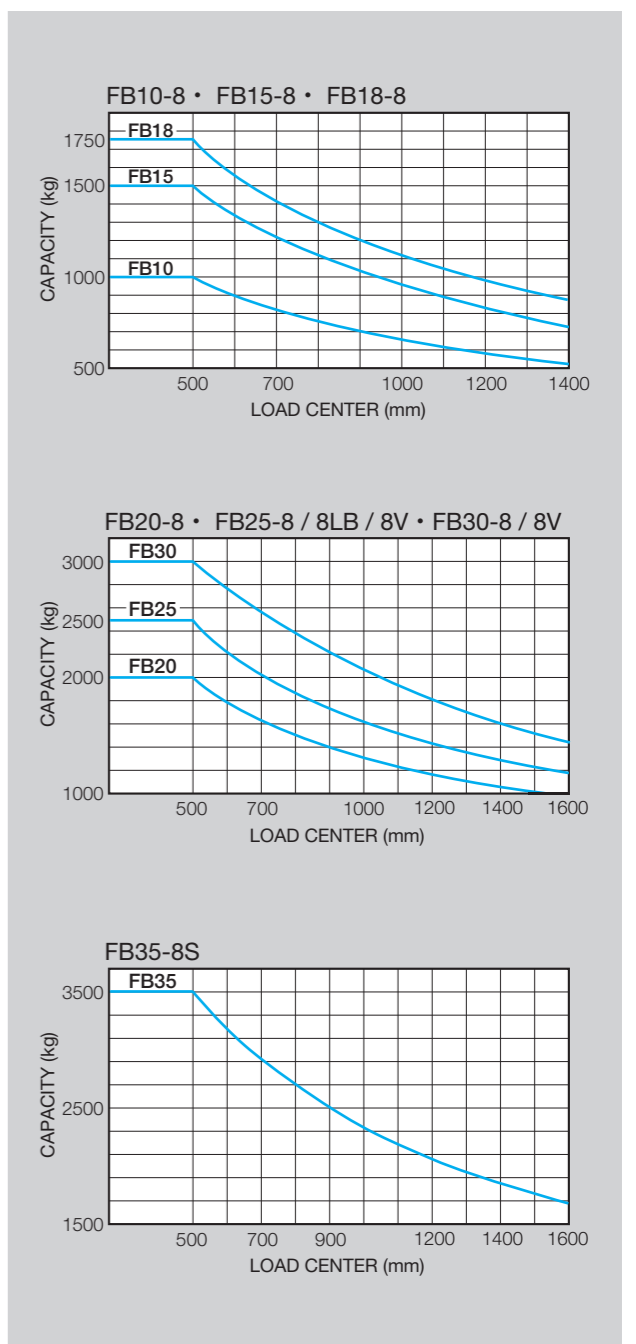

NOTES: ● Meets following major industrial standards and code:
 ISO 1074 Counter balanced lift trucks, stability & safety tests
 ISO 3691 Power industrial trucks-safety code
 ISO/DIS 3691 Travel & loading interlock
 ISO 6292 Power industrial trucks brake performance and component strength
 ISO 6055 Overhead guard
 JIS D6001 Power industrial trucks - safety code
 JIS D6011 Industrial trucks - stability & safety tests
 JIS D6021 Overhead guard
 JIS D6023 Industrial trucks brake performance & Safety tests
 ● In conformity with provision of the Machinery Directive 98/37/EC, as amended, and with National implementing legislation (for EXE/EXN configuration)

WIDE VIEW MAST

Wide View Mast VM

Mast Model	Capacity at 500mm : Load Center		Overall Mast Height		Tilting Angle	Service Weight (with battery)
	FB35-8S	Max. Fork Height	Lowered	Raised with Backrest		
					kg	mm
VM200	3500	2000	1635	3260	6-10	5145
VM250	3500	2500	1885	3760	6-10	5195
VM270	3500	2700	1985	3960	6-10	5215
VM300	3500	3000	2135	4260	6-10	5240
VM330	3500	3300	2285	4560	6-10	5270
VM350	3500	3500	2385	4760	6-10	5290
VM370	3500	3700	2485	4960	6-6 *6-10	5310
VM400	3500	4000	2685	5260	6-6 *6-10	5385
VM450	3400	4500	2935	5760	6-6 *6-10	5430
VM500	3300	5000	3185	6260	6-6 *6-6	5480
VM550	*3200	5500	3485	6760	*3-6	5565
VM600	*2850	6000	3735	7260	*3-6	5610

NOTE: Rated capacity with (*): Shows capacity with front dual tires.

Wide View Full Free 3-stage Mast VFHM

Mast Model	Capacity at 500mm : Load Center		Overall Mast Height			Tilting Angle	Service Weight (with battery)
	FB35-8S	Max. Fork Height	Lowered	Raised with Backrest	Free lift with Backrest		
						kg	mm
VFHM360	3400	3600	1885	4860	655	6-6 *6-10	5570
VFHM400	3400	4000	2010	5260	785	6-6 *6-10	5600
VFHM435	3300 *3400	4350	2135	5610	905	6-6 *6-10	5640
VFHM480	3300 *3300	4800	2285	6060	1055	6-6 *6-10	5665
VFHM500	3200 *3200	5000	2385	6260	1155	6-6 *6-10	5690
VFHM550	2650 *3100	5500	2550	6760	1320	3-6	5730
VFHM600	2000 *2800	6000	2735	7260	1505	3-6	5830

NOTE: Lifting speed with VFHM mast: (3.5t model) 220mm/s with load. 380mm/s without load. Lowering speed with VFHM mast: (3.5t model) 440mm/s with load. 380mm/s without load.

BATTERY

BATTERY SELECTION TABLE (option)

●: Standard capacity type ○, △: High capacity type

Battery voltage / capacity (Ah)	Battery case size (Inside L x W x H mm)	Model																		
		FB10-8	FB15-8	FB18-8	FB20-8	FB25-8	FB25-8LB	FB25-8V	FB30-8	FB30-8V	FB35-8S									
48 / 330	588 x 968 x 420	●																		
48 / 400	588 x 968 x 420	○	●																	
48 / 400	753 x 968 x 420			●																
48 / 450	768 x 1018 x 420				●															
48 / 485	588 x 968 x 420	○	○																	
	753 x 968 x 420			○																
48 / 545	653 x 968 x 420		△																	
	753 x 968 x 420			○																
48 / 565	768 x 1018 x 420				○	●														
48 / 600	768 x 1018 x 420				○	○														
48 / 700	833 x 1018 x 420				△	△														
48 / 865	833 x 1018 x 500						○	●												
48 / 935	978 x 1018 x 500						●	●												
72 / 450	883 x 1068 x 420							●	●											
72 / 450	978 x 1068 x 420								●											
72 / 485	883 x 1068 x 420								○	○										
72 / 545	978 x 1068 x 420								△										○	
Battery weight range (Min.-Max.kg)		600~740	640~850	900~1050	700~1090	850~1090	1280~1490	1070~1290	1200~1290											

NOTE: △: Battery case, bonnet, side panels and relative individual components are changed as compared with standard capacity type.

DIMENSIONS

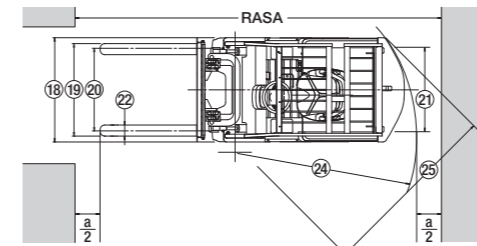

$$RASA = (24) + (11) + (10) + a (a=200mm)$$

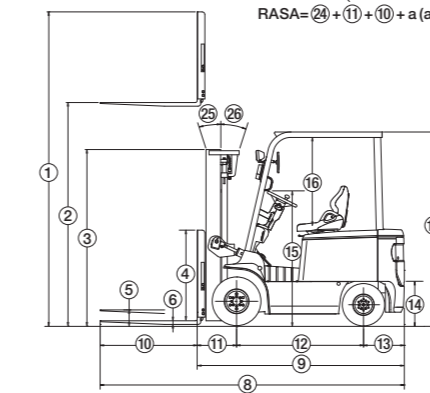

Ground-clearance (mm)	FB10-8 FB15-8 FB18-8	FB20-8 FB25-8	FB25-8LB FB25-8V	FB30-8 FB30-8V	FB35-8S
Mast	105	110	110	140	145
Frame	95	115	115	120	120
Front axle	90	100	100	140	140
Rear axle	90	100	90	90	90
Counter weight	125	135	135	135	135

INSTRUMENTS & CONTROLS

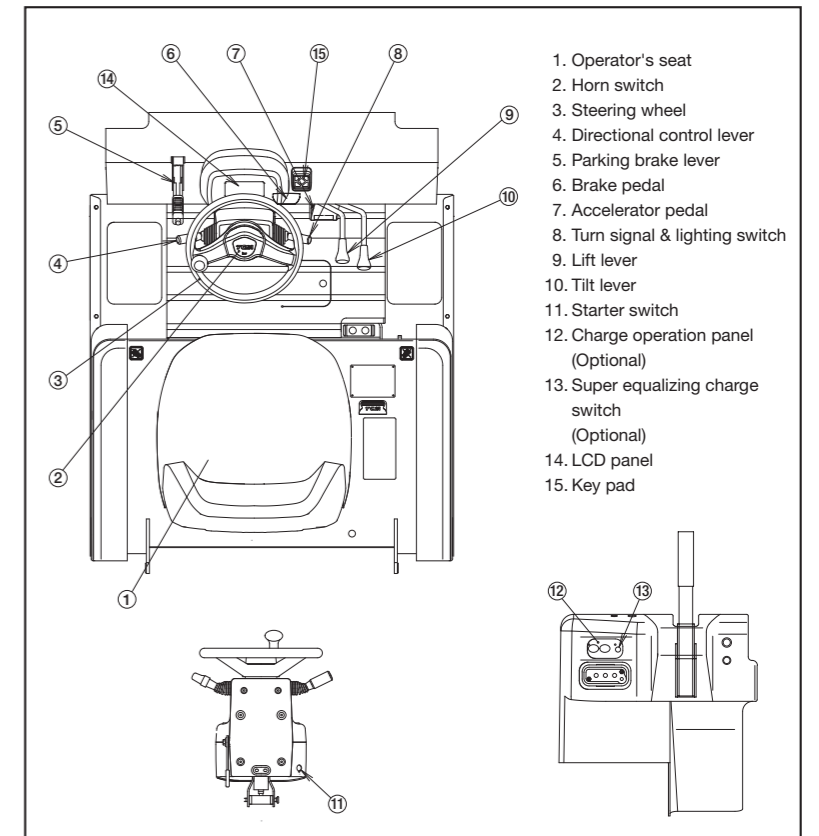

- Operator's seat
- Horn switch
- Steering wheel
- Directional control lever
- Parking brake lever
- Brake pedal
- Accelerator pedal
- Turn signal & lighting switch
- Lift lever
- Tilt lever
- Starter switch
- Charge operation panel (Optional)
- Super equalizing charge switch (Optional)
- LCD panel
- Key pad

STANDARD DIMENSIONS

MODEL	FB10-8	FB15-8	FB18-8	FB20-8	FB25-8	FB25-8LB FB25-8V	FB30-8 FB30-8V	FB35-8S
	mm	mm	mm	mm	mm	mm	mm	mm
① Overall height, fork raised (with backrest)	4030	4030	4030	4030	4030	4030	4260	4260
② Maximum fork height	3000	3000	3000	3000	3000	3000	3000	3000
③ Mast height, fork lowered	1995	1995	1995	2030	2030	2180 (2030)	2075	2135
④ Backrest height	1000	1000	1000	1000	1000	1000	1220	1220
⑤ Free lift	155	155	155	110	110	110	165	170
⑥ Fork thickness	35	35	35	40	40	40	45	50
⑦ Minimum under-clearance	90	90	90	100	100	90	90	90
⑧ Overall length (with forks)	2875	2875	2975	3315	3355	3460	3580	3805
⑨ Overall length (without forks)	1955	1955	2055	2245	2285	2390	2510	2735
⑩ Fork length	920	920	920	1070	1070	1070	1070	1070
⑪ Fork overhang	375	375	375	435	435	435	480	500
⑫ Wheelbase	1250	1250	1350	1400	1400	1545	1600	1800
⑬ Rear overhang	330	330	330	410	450	410	430	435
⑭ Drawbar height	390	390	390	440	440	440	475	475
⑮ Steering wheel height*	1350	1350	1350	1395	1395	1475	1515	1515
⑯ Overhead guard clearance (from face of seat)**	1020	1020	1020	1020	1020	1050 (980)	1080 (1000)	1080
⑰ Overall height (overhead guard)**	2080	2080	2080	2125	2125	2250 (2100)	2190 (2100)	2190
⑱ Overall width	1070	1070	1070	1150	1150	1150	1225	1380
⑲ Lateral fork adjustment (outside)	200 ~ 920	200 ~ 920	200 ~ 920	245 ~ 1020	245 ~ 1020	245 ~ 1020	250 ~ 1090	300 ~ 1090
⑳ Tread (front)	910	910	910	955	955	955	1000	1140
㉑ Tread (rear)	900	900	900	950	950	950	950	950
㉒ Fork width	100	100	100	122	122	122	125	150
㉓ Outside turning radius	1800 (1700 ¹⁾)	1800 (1700 ¹⁾)	1890 (1790 ¹⁾)	2070 (1950 ¹⁾)	2100 (1970 ¹⁾)	2200 (2065 ¹⁾)	2290 (2140 ¹⁾)	2500 (2360 ¹⁾)
㉔ Minimum intersecting aisle	1690	1690	1730	1895	1905	1955	2050	2250
㉕ Tilt angles (forward-backward)	6° - 12°	6° - 12°	6° - 12°	6° - 12°	6° - 12°	6° - 12°	6° - 12°	6° - 10°

NOTE: () for V models * In Scandinavian export trucks +70mm except V model ** In European and Scandinavian export trucks +60mm except V model
1) Figures are given for trucks with optional EPS

DIMENSIONS WITH FRONT DUAL DRIVE WHEELS (option)

MODEL	FB10-8	FB15-8	FB18-8	FB20-8	FB25-8	FB25-8LB FB25-8V	FB30-8 FB30-8V	FB35-8S
	mm	mm	mm	mm	mm	mm	mm	mm
Tire size (front dual)	4.50-12-8PR	4.50-12-8PR	4.50-12-8PR	6.00-9-10PR	6.00-9-10PR	6.00-9-10PR	6.00-15-10PR	6.00-15-10PR
Service weight	+40kg	+40kg	+40kg	+70kg	+70kg	+70kg	+18kg	+0kg
⑱ Overall width	1270	1270	1270	1485	1485	1485	1520	1520
⑳ Tread (front)	1055	1055	1055	1140	1140	1140	1170	1170
㉑ Outside turning radius	1840 (1745 ¹⁾)	1840 (1745 ¹⁾)	1920 (1825 ¹⁾)	2100 (1970 ¹⁾)	2130 (1955 ¹⁾)	2220 (2085 ¹⁾)	2310 (2180 ¹⁾)	2510 (2400 ¹⁾)
㉒ Minimum intersecting aisle	1780	1780	1825	2035	2045	2075	2160	2300

NOTE: 1) Figures are given for trucks with optional EPS

■ STANDARD EQUIPMENTS AND ACCESSORIES

[Equipment]

- Anti-roll back system
- Asbestos-free brake
- Auto power off system (PAO)
- Brake fluid reservoir tank
- Cylinder type bonnet stay with locking function
- Deluxe suspension seat with safety belt ¹⁾
- Drawbar device
- Durable overhead guard
- Fork length:920mm (1-1.8ton),1070mm (2-3.5ton)
- ITA Class II,III carriage
- Level gauge for hydraulic oil
- Lift circuit cut-off valve
- Load backrest (BRE)
- Load check valve
- Orbitrol fully-hydraulic power steering
- Regenerative braking system
- Return hydraulic filter
- Rib-lug tires
- Shock less lift-cylinder
- Suction hydraulic strainer
- Tilt adjustable steering post
- Tilt lock valve
- Traveling interlock system ²⁾
- Wide view mast
- 2-spool control valve with pressure relief valve

■ OPTIONAL LOADING ATTACHMENTS

- Fork extension sleeves (EF)
- Fork positioner (hydraulic, manual type) (FS,FSM)
- High, wide type load backrest
- Load grab (LG)
- Load push-pull (PPC)
- Load stabilizer (STA)
- Long forks (LF)
- Rotating forks (hook-on, integral type) (RF)
- Rotating paper roll clamp (PR)
- Side shift (hook-on, integral type) (SS)
- Sleeve-in hook
- Turna fork
- Wide type fork carriage (WF)
- Wide view full free 2-stage (VFM) mast
- Wide view full free 3-stage (VFHM) mast

Others on request

[Controls]

- Electric controlled direction change lever
- Lift and tilt levers
- Parking brake system with inter-lock
- Power mode (Super / Power / Economy) select switch
- Speed control (SC) switch
- Turn signal lights with self-cancelling mechanism

[Accessories]

- Back-up buzzer
- Document clip
- Document holder
- Electric horn
- Front combination lights (turn signal, clearance)
- Head lights
- Hand grip
- High-mounted rear combination lights (tail, brake, back-up, turn signal and reflector)
- Large rubber floor mat
- Operator tool kit
- Side view mirrors

[Instruments and Switch]

- Combined type switch lever (lighting & turn signal)
- Main key switch (LCD digital display)
- Battery charge / discharge level indicator
- Battery discharge warning indicator
- Contoroller overheat warning indicator
- Drive motor overheat warning indicator
- Hourmeter
- Neutral indicator & safety warning
- Ope. Seat switch ²⁾
- Parking brake indicator
- Power mode (Super / Power / Economy) indicator
- Self-diagnostic function display
- Speed control (SC) operating indicator
- Speedometer (SM)

■ OPTIONAL EQUIPMENTS AND ACCESSORIES

[Equipment]

- Auxiliary hyd.valve modules (3SV - 4SV)
- Battery ³⁾
- Battery chargers
- Central battery electrolyte refilling system (BCW)
- Cold-storage & fishery package (-35°C, -45°C) (FCS35, FCS45)
- Cold-storage package (-35°C) (CS35)
- Color solid tire (white, green)
- Electric power steering (EPS)
- F / R direction lever RH type (LCR)
- Fingertip control (FIT3SV - FIT4SV)
- Fishery industry package (FC)
- Front dual drive wheels
- High profile overhead guard (HGH060) ²⁾
- Leaser pointer
- Oil-filled lift cylinder (RTL)
- Solid tires (Unique cushion, Softone)
- Travel & loading interlock system (SIL) ²⁾
- Windowshield with wiper (AW071)
- 2-brake pedal configuration (BK2)

[Accessories]

- Battery container with hoisting bracket
- Beacon light,interlocked with back-up alarm (BBR)
- Buck-up buzzer with volume switch (BBA)
- Center rearview mirror (BMC)
- Chime (buzzer) for forward travelling (TAF)
- Custom coloring paint (P)
- Fire extinguisher (FE)
- Head light guard (HLG)
- LED beacon light (yellow & red) (RLR,RLY)
- Overhead guard canvas (HGC)
- Rear working light (RWL)
- Rust-proof painting (PRR)
- Steel net (for overhead guard) (HGD) ¹⁾
- Tilt cylinder boots (TLB)

Note : 1) Except V model trucks

2) Standard specification for EXC, EXE & EXN configuration

3) Refer to the battery selection table

- TCM retains the right to change these products and specifications without incurring any obligation relating to such changes.
- These products and specifications are subject to change without notice.
- Photos and illustrations may or may not include optional equipment and accessories.
- Features and specifications may vary depending on markets.



ISO 9001 Certification
(TCM Shiga Plant)



ISO 14001 Certification
(TCM Shiga Plant)

Manufactured by

TCM[®]
TCM CORPORATION

1-15-10, Kyomachi-bori, Nishi-ku,
Osaka, 550-0003, Japan
TEL: +81-6-7669-8906
FAX: +81-6-7669-8916
<http://www.tcmglobal.net>

Distributed by